

## **eSentinel™ Series 1.00P Specifications and Programming**

---

### **Important !!**

Plug unit in for 24 hours to charge battery before installing for monitoring purposes.

### **eSentinel Pager Event Reporting**

When a eSentinel detects a specified event (Contact Closure 1, Contact Closure 2 or Power on) it will wait a pre-determined amount of time. During this wait period it will periodically check the event status to see if it has corrected itself. After the time expires, if the event is still active, it will dial a pre-programmed pager number and send the pre-programmed event message and the event code for the action that caused the event notification to be triggered. The technician will be able to read the information from the pager display and take the appropriate action required. The eSentinel has been designed for flexible program parameters to be compatible with most or all pagers and paging systems.

#### **Example Pager Report**

If you programmed the eSentinel event message to “2086587398” and a Contact Closure 1 event occurred you would get a call to your pager to notify you that an event has occurred. The following information would be displayed on your pager.

2086587398 01

The “01” at the end of the event message is the event code and signifies that a Contact Closure 1 event occurred. The following are valid event codes:

01 = Contact closure 1 event

02 = Contact closure 2 event

03 = Power on (This event occurs when power is restored after a power failure or outage)

\*\* Power on event feature is disabled on the eSentinel with battery backup\*\*

### **eSentinel Hardware**

The eSentinel has 3 external connections, dry contact connections, telephone line and external power source.

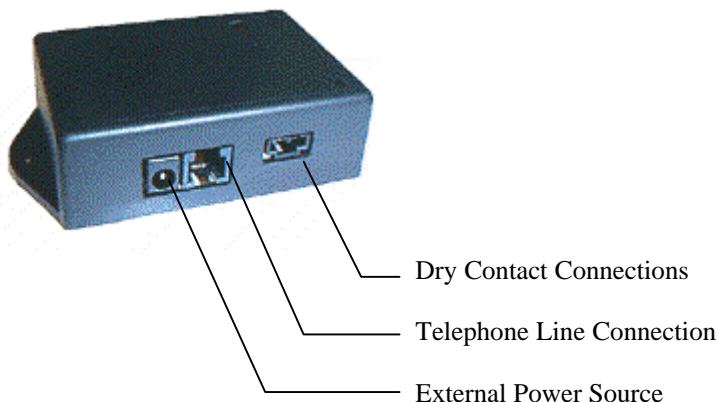

## Dry Contact Connector Schematic Diagram

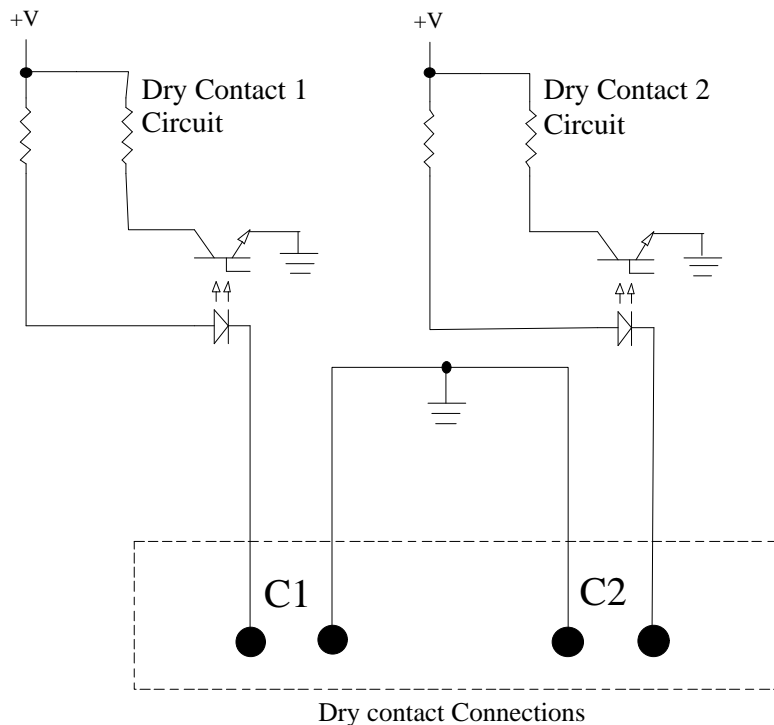

To utilize C1 and C2 connections connect them to a normally open or normally closed dry contact closure. When the relay changes to the non-normal condition the *e*Sentinel will start its event reporting process.

## *e*Sentinel Programming

To program the *e*Sentinel you will need a touch tone telephone connected to the same phone line as *e*Sentinel or another device that can generate touchtones. To enter programming go off hook with the phone connected to the same telephone line as the *e*Sentinel and dial “\*5\*4801\*” you will then hear a single beep signifying that you are now in program mode. If you accidentally enter the wrong program password wait 10 seconds then re-enter the password. During programming if you do not enter any program data for 1 minute it will beep 4 times then exit program mode automatically. To exit programming dial “\*\*1”.

### Program Registers

- Register 00 (Pager telephone number):
- Register 01 (Numeric event message):
- Register 02 (Event report delay):
- Register 03 (Time to wait for connect before call failure):
- Register 04 (Attempts to connect on call failure):
- Register 05 (Dial type):
- Register 06 (Dtmf dial interval):
- Register 07 (Contact 1 normal state):
- Register 08 (Contact 2 normal state):
- Register 09 (Power on event enable\disable):
- Register 10 (Page end dtmf command):
- Register 96 (Default *e*Sentinel to factory settings):
- Register \*\* (Exit program mode):

## **eSentinel Program Registers**

### **Special Notes For Programming Registers 00, 01, 10**

These registers are all ended by ## so you are not able to program a # literally into these registers. When programming registers 00, 01, 02 use the below format:

1,2,3,4,5,6,7,8,9,0,\* are literal

#1 = Dtmf #

#2 = Pause 500ms

#3 = Dtmf B

#3 = Dtmf C

#4 = Dtmf D

**Register 00 (Pager telephone number):** Default = 5555555 : Maximum Length = 20

This is where you program the number of the pager to be called when an event occurs. If not already in programming enter into program mode by dialing “\*5\*4801\*” and wait for single beep, then dial 00 and you will here a single beep, then dial the telephone number of the pager to be called then dial ## and wait for 2 beeps, if you here 4 beeps then a error occurred in the entry. Example (00 “beep” 5555555 ## “beep beep”).

**Register 01 (Numeric event message):** Default = 1234 : Maximum Length = 20

This is where you program the event message to identify the location or account of where eSentinel is installed. This is the numeric message that will be displayed on the pager. If not already in programming enter into program mode by dialing “\*5\*4801\*” and wait for single beep, then dial 01 and you will here a single beep, then dial the numeric message you want displayed on the pager when an event call is made then dial ## and wait for 2 beeps, if you here 4 beeps then a error occurred in the entry. Example (01 “beep” 1017891234 ## “beep beep”).

**Register 02 (Event report delay):** Default = 300 Seconds

This is where you program the event report delay. This is the amount of time the eSentinel waits before sending an event call to the pager. During this waiting period the eSentinel will continue to check the status of the contacts, if the contacts return to their normal state during this wait period the event is canceled and no event call is made. If not already in programming enter into program mode by dialing “\*5\*4801\*” and wait for single beep, then dial 02 and you will here a single beep, then dial the report delay in seconds (1 to 9999) then dial ## and wait for 2 beeps. If you here 4 beeps then a error occurred in the entry. Example (02 “beep” 60 ## “beep beep”).

**Register 03 (Time to wait for connect before call failure):** Default = 30 Seconds

This is where you program the amount of time the eSentinel waits for the pager to answer. If a call is made to a pager and the pager does not respond by this specified amount of time then the eSentinel will hang up and retry the event call “xx” times specified by “Register 04. If not already in programming enter into program mode by dialing “\*5\*4801\*” and wait for single beep, then dial 03 and you will here a single beep, then dial the time to wait in seconds (1 to 255) then dial ## and wait for 2 beeps. If you here 4 beeps then a error occurred in the entry. Example (03 “beep” 20 ## “beep beep”).

**Register 04 (Attempts to connect on call failure):** Default = 15 Times

This is where you program the amount of time the eSentinel will retry an event call before aborting. If not already in programming enter into program mode by dialing “\*5\*4801\*” and wait for single beep, then dial 04 and you will here a single beep, then dial the number of attempts (1 to 15) then dial ## and wait for 2 beeps. If you here 4 beeps then a error occurred in the entry. Example (04 “beep” 7 ## “beep beep”).

**Register 05 (Dial type):** Default = 1 for Dtmf

The *e*Sentinel can dial the pager number in pulse or dtmf. Enter into programming mode if not already by dialing “\*5\*4801\*” and wait for a single beep then dial 05 and you will hear a single beep, then dial 1 for dtmf or 2 for pulse and wait for 2 beeps. If you here 4 beeps then a error occurred in the entry. Example (05 “beep” 1 “beep beep”).

**Register 06 (Dtmf dial interval):** Default = 75 Milliseconds

The dtmf dial interval for *e*Sentinel can be set via this program register. If you are having communication problems with the numeric pager you may try to slow down the dtmf dial interval. To change the dtmf dial interval enter into programming mode if not already by dialing “\*5\*4801\*” and wait for a single beep then dial 06 and you will hear a single beep, then dial dtmf interval in milliseconds (40 to 150) then dial ## and wait for 2 beeps. If you here 4 beeps then a error occurred in the entry. Example (06 “beep” 7 5 “beep beep”).

**Register 07 (Contact 1 normal state):** Default = 1 for Normally Open

Dry contact closure 1, normal state, can be configured for normally closed or normally open. The event call is made when the contact is not in its configured normal state. To program the contacts normal state enter into programming mode, if not already, by dialing “\*5\*4801\*” and wait for a single beep then dial 07 and you will hear a single beep, then dial 1 for “normally open” or 2 for “normally closed” and wait for 2 beeps. If you here 4 beeps then a error occurred in the entry. Example (07 “beep” 1 “beep beep”).

**Register 08 (Contact 2 normal state):** Default = 1 for Normally Open

Dry contact closure 2, normal state, can be configured for normally closed or normally open. The event call is made when the contact is not in its configured normal state. To program the contacts normal state enter into programming mode, if not already, by dialing “\*5\*4801\*” and wait for a single beep then dial 08 and you will hear a single beep, then dial 1 for “normally open” or 2 “for normally closed” and wait for 2 beeps. If you here 4 beeps then a error occurred in the entry. Example (08 “beep” 1 “beep beep”).

**Register 09 (Power on event enable/disable):** Default = 2 for Disabled

The *e*Sentinel can be configured to make an event call when the unit’s power is restored after a power failure. To enable or disable this feature enter into programming mode, if not already, by dialing “\*5\*4801\*” and wait for a single beep then dial 09 and you will hear a single beep, then dial 1 to enable or 2 to disable power on event and wait for 2 beeps. If you here 4 beeps then a error occurred in the entry. Example (09 “beep” 1 “beep beep”).

**Register 10 (Page end dtmf command):** Default = Empty : Maximum Length = 4

Some pager systems require you to enter a # or other dtmf to signify the end of the numeric message. The digits you program into this register will be dialed at the end of the event call dtmf string. To program this register enter into programming mode, if not already, by dialing “\*5\*4801\*” and wait for a single beep then dial 10 and you will hear a single beep, then dial the “Page End Command” followed by ## and wait for 2 beeps. If you here 4 beeps then a error occurred in the entry. Example (10 “beep” \* ## “beep beep”).

**Register 96 (Default *e*Sentinel to factory settings):**

To default the *e*Sentinel to factory settings enter into programming mode, if not already, by dialing “\*5\*4801\*” and wait for a single beep then dial 96 and you will hear a single beep, then dial 1 to default or 2 to not default and wait for 2 beeps. If you here 4 beeps then a error occurred in the entry. Example (96 “beep” 1 “beep beep”).

**Register \*\* (Exit program mode):**

To exit *e*Sentinel program mode dial \*\* and wait for 1 beep, then dial 1 and wait for 2 beeps and hang up the telephone.

## Setting up Your Pager to Accept *e*Sentinel Event Calls

To enable the *e*Sentinel to communicate with your pager you need to record a dtmf tone at the end of your voice greeting. To accomplish this, record you’re greeting then dial any single number on your telephone keypad. Some pager services will not allow you to record certain dtmf tones so you may have to experiment a little with this procedure. We recommend using dtmf “6” to start. If you pager service does not allow you to record a dtmf tone in your voice greeting then you will have to do the following steps:

1. Program **Register 04 (Attempts to connect on call failure)** to 0.
2. Program **Register 03 (Time to wait for connect before call failure)** to however long it takes for your pager service to answer.
3. When the eSentinel makes an event call it will dial the pager number and wait the amount of seconds programmed in Register 03 and then it will dial the numeric message.